

420 (410) and 465 (464) Product Overview

Digital 3E^{TECH} 420 (410) and 465 (464) FINE BORING

Make easy diameter adjustments with our 3E^{TECH} digital readout module.

Wohlhaupter® 420 (410) and 465 (464) digital boring heads are equipped with a 3E^{TECH} docking port for easy digital adjustments. Boring heads from 1.142" (29.00 mm) and up offer precision boring with automatic balancing. Our boring heads are specifically engineered to minimize the residual imbalance produced by insert holder displacement. Wohlhaupter Alu-Line boring heads, ranging from 2.559" (65.00 mm) and up, offer a lightweight aluminum design with a wear-resistant coating that reduces weight on the spindle up to 50%. The insert holder can also be rotated for reverse machining jobs.

- Unbalanced 420 (410) diameter range: 0.787" - 1.142" (20.00 mm - 29.00 mm)
- Balanced 465 (464) diameter range: 1.142" - 8.071" (29.00 mm - 205.00 mm)
- Balanced 465 (464) Alu-Line diameter range: 2.559" - 8.071" (65.00 mm - 205.00 mm)
 - Special coating on Alu-Line for wear-resistant surface
 - Alu-Line body reduces tool weight by 50%, reducing stress on the spindle
- Coolant through
- 3E^{TECH} and vernier diameter adjustment of 0.0001" (0.002 mm)
- Internal balancing improves tool life and surface finish
- Insert holder can be rotated for back boring jobs
- Max cutting speed: 5,577 SFM (1,700 m/min)

Highly accurate adjustments through vernier scale



NOTE: Imperial items pictured

NOTE: Adjustment accuracy of 0.0001" or 0.002 mm on diameter

Versatile 3E^{TECH} digital readout compatible with other boring tools

IMPORTANT: Max spindle speed refers to maximum possible speed for an individual boring head and is not a recommended parameter. Refer to page B10-M: 12 for recommended application-specific parameters. Factory technical assistance is available for your specific applications through our Application Engineering department.
ext: 7611 | email: appeng@alliedmachine.com

WOHLHAUPTER® 420 (410) and 465 (464) 3E^{TECH} DIGITAL BORING HEADS

Wohlhaupter 3E^{TECH}

Improve productivity and quality with the Wohlhaupter 3E^{TECH} external digital readout module. The 3E^{TECH} docks onto boring heads and cassettes that offer the 3E^{TECH} port to make easy diameter adjustments at the machine.

- Make quick and easy micron-accurate diameter adjustments
- Easy-to-read digital display shows exact diameter adjustments
- Designed to be removed from boring tool before operation (if forgotten 3E^{TECH} will fall off at 500 RPM)
- Adjustments of 0.0001" (0.002 mm) on diameter
- Available in imperial and metric
- Water and dust resistant IP 56
- Coolant and chip resistant
- 3E^{TECH} will automatically turn off after 30 seconds of not using
- WEEE-Reg.-Nr. DE 15820388

- ✓ High-production fine boring
- ✓ Easy diameter adjustment with 3E^{TECH}
- ✓ Self-balancing 465 (464) boring heads
- ✓ Imperial and metric

NEW 420 (410) & 465 (464) BORING HEADS WITH 3E ^{TECH}		
	Diameter Range	Part No.
i	0.787 - 0.965	420001
	0.965 - 1.142	420002
	1.142 - 1.496	465003
	1.496 - 1.969	465004
	1.969 - 2.579	465005
	2.559 - 3.268	465006
	3.228 - 4.055	465007
	3.937 - 5.118	465008
	4.921 - 6.594	465009
	6.398 - 8.071	465010
m	20.00 - 24.50	410001
	24.50 - 29.00	410002
	29.00 - 38.00	464003
	38.00 - 50.00	464004
	50.00 - 65.50	464005
	65.00 - 83.00	464006
	82.00 - 103.00	464007
	100.00 - 130.00	464008
	125.00 - 167.50	464009
	162.50 - 205.00	464010



NOTE: Imperial items pictured

IMPORTANT: Max spindle speed refers to maximum possible speed for an individual boring head and is not a recommended parameter. Refer to page B10-M: 12 for recommended application-specific parameters. Factory technical assistance is available for your specific applications through our Application Engineering department.
ext: 7611 | email: appeng@alliedmachine.com

420 (410) Unbalanced Boring Heads with 3E^{TECH}

Diameter Range: 0.787" - 1.142" (20.00 mm - 29.00 mm)



Form 101

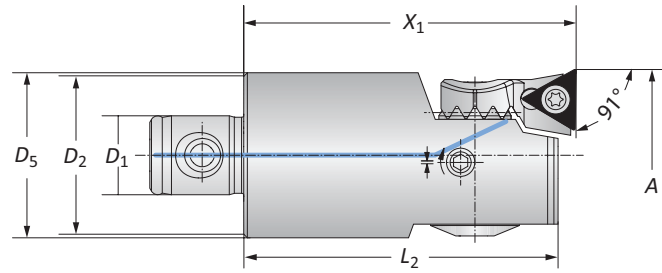

Form 20

420 Unbalanced Boring Heads with 3E^{TECH}

	MVS Connection	Boring Range	Boring Head			Weight	Insert Form	Part No.	
	D ₂ D ₁	A	X ₁	L ₂	D ₅			Insert Holder	Boring Head
	19 - 11	0.787 - 0.965	1.811	1.693	–	0.198 (lbs)	20*	364077	420001
i	22 - 11	0.965 - 1.142	1.811	1.713	0.906	0.286 (lbs)	20	210059	420002
	22 - 11	0.965 - 1.142	1.811	1.713	0.906	0.286 (lbs)	101	210069	420002

*Not suitable for indexable inserts with a radius of 0.031" (0.80 mm)

NOTE: 3E^{TECH} module, insert holders, and inserts sold separately

410 Unbalanced Boring Heads with 3E^{TECH}

	MVS Connection	Boring Range	Boring Head			Weight	Insert Form	Part No.	
	D ₂ D ₁	A	X ₁	L ₂	D ₅			Insert Holder	Boring Head
	19 - 11	20.00 - 24.50	46.00	43.00	–	0.09 (kg)	20*	364077*	410001
m	22 - 11	24.50 - 29.00	46.00	43.50	23.00	0.13 (kg)	20	210059	410002
	22 - 11	24.50 - 29.00	46.00	43.50	23.00	0.13 (kg)	101	210069	410002

*Not suitable for indexable inserts with a radius of 0.031" (0.80 mm)

NOTE: 3E^{TECH} module, insert holders, and inserts sold separately



3E^{TECH} Digital Readout Module

	Part No.
i	563010
m	536010

NOTE: WEEE-Reg.-Nr. DE 15820388

NOTE: 3E^{TECH} sold separately

NOTE: Imperial item pictured

NOTE: Adjustment accuracy of 0.0001" or 0.002 mm on diameter

Key on B10-B: 1

B10-M: 12-15

B10-F

B10: vi-vii

i = Imperial (in)
m = Metric (mm)

IMPORTANT: Max spindle speed refers to maximum possible speed for an individual boring head and is not a recommended parameter. Refer to page B10-M: 12 for recommended application-specific parameters. Factory technical assistance is available for your specific applications through our Application Engineering department.
ext: 7611 | email: appeng@alliedmachine.com

465 (464) Balanced Boring Heads with 3E^{TECH}

Diameter Range: 1.142" - 2.579" (29.00 mm - 65.50 mm)



Form 101

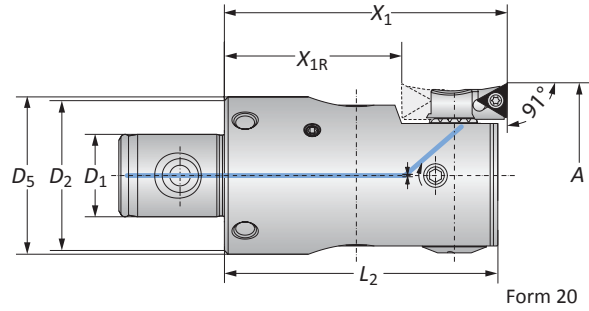

Form 20

465 Balanced Boring Heads with 3E^{TECH}

	MVS Connection		Boring Range				Boring Head				Part No.	
	D_2 D_1	A	X_1	X_{1R}	L_2	D_5	Weight	Insert Form	Insert Holder	Boring Head		
i	25 - 14	1.142 - 1.496	2.205	-	2.106	1.063	0.463 (lbs)	20	210059	465003		
	25 - 14	1.142 - 1.496	2.205	-	2.106	1.063	0.463 (lbs)	101	210069	465003		
	32 - 18	1.496 - 1.969	2.598	1.496	2.500	1.339	0.904 (lbs)	20	264051	465004		
	32 - 18	1.496 - 1.969	2.598	1.496	2.500	1.339	0.904 (lbs)	101	264077	465004		
	40 - 22	1.969 - 2.579	2.953	1.850	2.854	1.654	1.764 (lbs)	20	210052	465005		
	40 - 22	1.969 - 2.579	2.953	1.850	2.854	1.654	1.764 (lbs)	101	210062	465005		

NOTE: X_{1R} = rotated insert holder for reverse machining
 NOTE: 3E^{TECH} module, insert holders, and inserts sold separately

464 Balanced Boring Heads with 3E^{TECH}

	MVS Connection		Boring Range				Boring Head				Part No.	
	D_2 D_1	A	X_1	X_{1R}	L_2	D_5	Weight	Insert Form	Insert Holder	Boring Head		
m	25 - 14	29.00 - 38.00	56.00	-	53.50	27.00	0.21 (kg)	20	210059	464003		
	25 - 14	29.00 - 38.00	56.00	-	53.50	27.00	0.21 (kg)	101	210069	464003		
	32 - 18	38.00 - 50.00	66.00	38.00	63.50	34.00	0.41 (kg)	20	264051	464004		
	32 - 18	38.00 - 50.00	66.00	38.00	63.50	34.00	0.41 (kg)	101	264077	464004		
	40 - 22	50.00 - 65.50	75.00	47.00	72.50	42.00	0.80 (kg)	20	210052	464005		
	40 - 22	50.00 - 65.50	75.00	47.00	72.50	42.00	0.80 (kg)	101	210062	464005		

NOTE: X_{1R} = rotated insert holder for reverse machining
 NOTE: 3E^{TECH} module, insert holders, and inserts sold separately



3E^{TECH} Digital Readout Module

Part No.	
i	563010
m	536010

NOTE: WEEE-Reg.-Nr. DE 15820388
 NOTE: 3E^{TECH} sold separately

NOTE: Imperial item pictured
 NOTE: Adjustment accuracy of 0.0001" or 0.002 mm on diameter

B10-M: 12-15

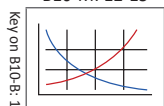

B10-F

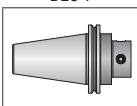

B10: vi-vii



i = Imperial (in)
 m = Metric (mm)

IMPORTANT: Max spindle speed refers to maximum possible speed for an individual boring head and is not a recommended parameter. Refer to page B10-M: 12 for recommended application-specific parameters. Factory technical assistance is available for your specific applications through our Application Engineering department.
 ext: 7611 | email: appeng@alliedmachine.com

465 Balanced Boring Heads with 3E^{TECH}

Imperial | Alu-Line | Diameter Range: 2.559" - 8.071"



Form 101

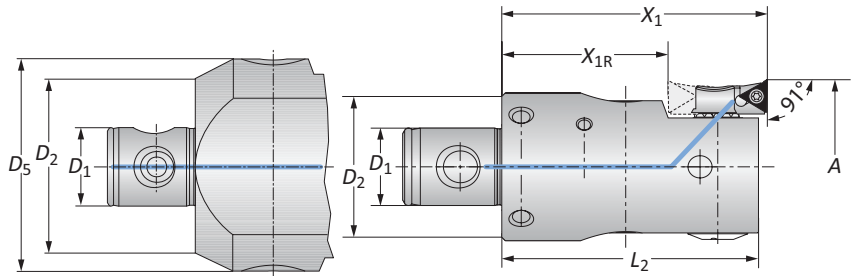

Form 20

465 Balanced Alu-Line Boring Heads with 3E^{TECH}

MVS Connection	Boring Range	Boring Head					Weight	Insert Form	Part No.	
		$D_2 D_1$	A	X_1	X_{1R}	L_2			D_5	Insert Holder
	50 - 28	2.559 - 3.268	2.953	1.535	2.874	-	1.323 (lbs)	20	210020	465006
	50 - 28	2.559 - 3.268	2.953	1.535	2.874	-	1.323 (lbs)	101	210063	465006
	50 - 28	2.559 - 3.268	2.953	1.535	2.874	-	1.323 (lbs)	103	210064	465006
	63 - 36	3.228 - 4.055	3.543	2.126	3.464	-	2.205 (lbs)	20	210020	465007
	63 - 36	3.228 - 4.055	3.543	2.126	3.464	-	2.205 (lbs)	101	210063	465007
	63 - 36	3.228 - 4.055	3.543	2.126	3.464	-	2.205 (lbs)	103	210064	465007
	80 - 36	3.937 - 5.118	3.543	2.126	3.464	-	3.307 (lbs)	20	210020	465008
i	80 - 36	3.937 - 5.118	3.543	2.126	3.464	-	3.307 (lbs)	101	210063	465008
	80 - 36	3.937 - 5.118	3.543	2.126	3.464	-	3.307 (lbs)	103	210064	465008
	80 - 36	4.921 - 6.594	3.543	2.126	3.464	3.937	3.307 (lbs)	20	210020	465009
	80 - 36	4.921 - 6.594	3.543	2.126	3.464	3.937	4.189 (lbs)	101	210063	465009
	80 - 36	4.921 - 6.594	3.543	2.126	3.464	3.937	4.189 (lbs)	103	210064	465009
	80 - 36	6.398 - 8.071	3.543	2.126	3.464	5.315	4.189 (lbs)	20	210020	465010
	80 - 36	6.398 - 8.071	3.543	2.126	3.464	5.315	4.189 (lbs)	101	210063	465010
	80 - 36	6.398 - 8.071	3.543	2.126	3.464	5.315	5.512 (lbs)	103	210064	465010

NOTE: X_{1R} = rotated insert holder for reverse machining
NOTE: 3E^{TECH} module, insert holders, and inserts sold separately



3E^{TECH} Digital Readout Module

Part No.
i 563010

NOTE: WEEE-Reg.-Nr. DE 15820388
NOTE: 3E^{TECH} sold separately

NOTE: Imperial item pictured
NOTE: Adjustment accuracy of 0.0001" or 0.002 mm on diameter

B10-M: 12-15 | B10-F | B10: vi-vii

i = Imperial (in)
m = Metric (mm)

IMPORTANT: Max spindle speed refers to maximum possible speed for an individual boring head and is not a recommended parameter. Refer to page B10-M: 12 for recommended application-specific parameters. Factory technical assistance is available for your specific applications through our Application Engineering department.
 ext: 7611 | email: appeng@alliedmachine.com



464 Balanced Boring Heads with 3E^{TECH}

Metric | Alu-Line | Diameter Range: 65.00 mm - 205.00 mm



Form 101

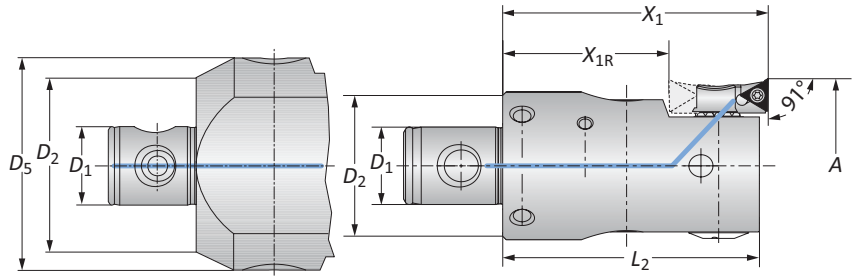

Form 20

464 Balanced Alu-Line Boring Heads with 3E^{TECH}

MVS Connection	Boring Range	Boring Head					Weight	Insert Form	Part No.	
		$D_2 D_1$	A	X_1	X_{1R}	L_2			D_5	Insert Holder
m	50 - 28	65.00 - 83.00	75.00	39.00	73.00	-	0.60 (kg)	20	210020	464006
	50 - 28	65.00 - 83.00	75.00	39.00	73.00	-	0.60 (kg)	101	210063	464006
	50 - 28	65.00 - 83.00	75.00	39.00	73.00	-	0.60 (kg)	103	210064	464006
	63 - 36	82.00 - 103.00	90.00	54.00	88.00	-	1.00 (kg)	20	210020	464007
	63 - 36	82.00 - 103.00	90.00	54.00	88.00	-	1.00 (kg)	101	210063	464007
	63 - 36	82.00 - 103.00	90.00	54.00	88.00	-	1.00 (kg)	103	210064	464007
	80 - 36	100.00 - 130.00	90.00	54.00	88.00	-	1.50 (kg)	20	210020	464008
	80 - 36	100.00 - 130.00	90.00	54.00	88.00	-	1.50 (kg)	101	210063	464008
	80 - 36	100.00 - 130.00	90.00	54.00	88.00	-	1.50 (kg)	103	210064	464008
	80 - 36	125.00 - 167.50	90.00	54.00	88.00	100.00	1.90 (kg)	20	210020	464009
	80 - 36	125.00 - 167.50	90.00	54.00	88.00	100.00	1.90 (kg)	101	210063	464009
	80 - 36	125.00 - 167.50	90.00	54.00	88.00	100.00	1.90 (kg)	103	210064	464009
	80 - 36	162.50 - 205.00	90.00	54.00	88.00	135.00	2.50 (kg)	20	210020	464010
	80 - 36	162.50 - 205.00	90.00	54.00	88.00	135.00	2.50 (kg)	101	210063	464010
	80 - 36	162.50 - 205.00	90.00	54.00	88.00	135.00	2.50 (kg)	103	210064	464010

NOTE: X_{1R} = rotated insert holder for reverse machining
 NOTE: 3E^{TECH} module, insert holders, and inserts sold separately



3E^{TECH} Digital Readout Module

Part No.
m 536010

NOTE: WEEE-Reg.-Nr. DE 15820388
 NOTE: 3E^{TECH} sold separately

NOTE: Imperial item pictured
 NOTE: Adjustment accuracy of 0.0001" or 0.002 mm on diameter

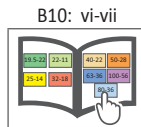
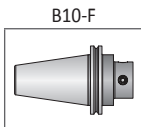
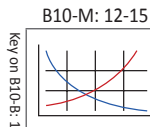

i = Imperial (in)
 m = Metric (mm)

IMPORTANT: Max spindle speed refers to maximum possible speed for an individual boring head and is not a recommended parameter. Refer to page B10-M: 12 for recommended application-specific parameters. Factory technical assistance is available for your specific applications through our Application Engineering department.
 ext: 7611 | email: appeng@alliedmachine.com

Insert Holders for Abrasive Materials

Diameter Range: 2.559" - 8.071" (65.00 mm - 205.00 mm)

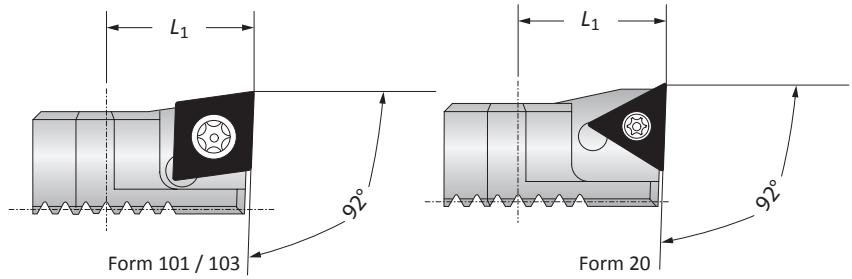

		Insert Holder			
Boring Range		L_1	Weight	Insert Form	Part No.
i	2.559 - 8.071	0.709	0.066 (lbs)	20	211061
	2.559 - 8.071	0.709	0.066 (lbs)	101	211063
	2.559 - 8.071	0.709	0.066 (lbs)	103	211065
m	65.00 - 205.00	18.00	0.03 (kg)	20	211061
	65.00 - 205.00	18.00	0.03 (kg)	101	211063
	65.00 - 205.00	18.00	0.03 (kg)	103	211065

NOTE: Insert holders used for abrasive materials to protect boring head against chip wash

NOTE: When machining grey cast iron, we recommend using insert holders for abrasive materials with CBN inserts for optimized chip removal.

B10-M: 12-15

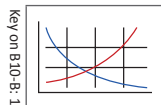

B10-H

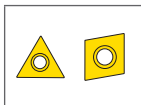

B10: vi-vii

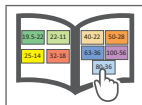

i = Imperial (in)
m = Metric (mm)

Inserts sold separately

Accessories

Screws | 3E^{TECH} Accessories

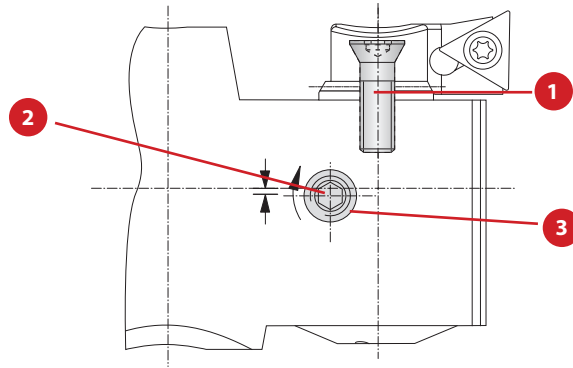

Boring Head	Part No.				
	1 Countersunk Screw	Countersunk Screw Service Key	2 Clamping Screw	Clamping Screw Service Key	3 Ball
420001 (410001)	215323	T15 / H	410151	S2 / A	364270
420002 (410002)	215338	T15 / H	410152	s2 / A	364270
465003 (464003)	215338	T15 / H	364138	s2.5 / A	364139
465004 (464004)	215338	T15 / H	115180	s2.5 / A	-
465005 (464005)	215338	T15 / H	115505	s3 / B	-
465006 (464006)	215462	T20 / H	315943	s4 / B	-
465007 (464007)	215462	T20 / H	515178	s4 / B	-
465008 (464008)	215462	T20 / H	515178	s4 / B	-
465009 (464009)	215462	T20 / H	515178	s4 / B	-
465010 (464010)	215462	T20 / H	515178	s4 / B	-

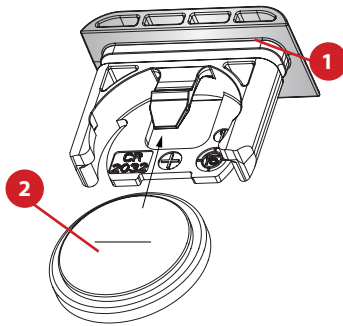

1 Sealing Ring	2 Battery CR2032
Part No.	Part No.
215483	515491

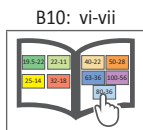
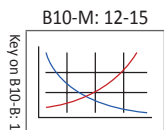

A
B
C
D
E
F
G
H
I
J
K
L
M
INDEX