

365 (364) and 465 (464) Product Overview

Balanced Analog 365 (364) and 465 (464) FINE BORING

Analog fine boring tools for high-production jobs

Wohlhaupter® 365 (364) and 465 (464) analog balanced boring heads offer precision boring with automatic balancing. Our boring heads are specifically engineered to minimize the residual imbalance produced by insert holder displacement. Wohlhaupter Alu-Line boring heads offer a lightweight aluminum design with a wear-resistant coating that reduces weight on the spindle up to 50% yet remains durable in challenging boring applications. The insert holder can also be rotated for reverse machining jobs.

- 365 (364) diameter range: 0.787" - 1.161" (20.00 mm - 29.50 mm)
- 465 (464) diameter range: 1.142" - 8.071" (29.00 mm - 205.00 mm)
- 465 (464) Alu-Line diameter range: 2.559" - 8.071" (65.00 mm - 205.00 mm)
 - Special coating on Alu-Line for wear-resistant surface
 - Alu-Line body reduces tool weight by 50%, reducing stress on the spindle
- Internal balancing improves tool life and surface finish
- Coolant through
- Vernier diameter adjustment of 0.0001" (0.002 mm)
- Insert holder can be rotated for back boring jobs
- Max cutting speed: 3,281 SFM (1,000 m/min)



IMPORTANT: Max spindle speed refers to maximum possible speed for an individual boring head and is not a recommended parameter. Refer to page B10-M: 12 for recommended application-specific parameters. Factory technical assistance is available for your specific applications through our Application Engineering department.
ext: 7611 | email: appeng@alliedmachine.com

WOHLHAUPTER® 465 (464) BALANCED ANALOG BORING HEADS

ANALOG BORING HEAD PART NUMBER CONVERSION			
Diameter Range	Old Part No.	<i>NEW</i> Part No.	
i	0.787 - 0.965	365030	<i>No Change</i>
	0.965 - 1.161	365031	<i>No Change</i>
	1.142 - 1.516	365032	465033
	1.496 - 1.988	365033	465034
	1.969 - 2.579	365034	465035
	2.559 - 3.268	365045	465036
	3.228 - 4.055	365046	465037
	3.937 - 5.118	365047	465038
	4.921 - 6.594	365048	465039
6.398 - 8.071	365049	465040	
m	20.00 - 24.50	364030	<i>No Change</i>
	24.50 - 29.50	364031	<i>No Change</i>
	29.00 - 38.00	364032	464033
	38.00 - 50.00	364033	464034
	50.00 - 65.50	364034	464035
	65.00 - 83.00	364045	464036
	82.00 - 103.00	364046	464037
	100.00 - 130.00	364047	464038
	125.00 - 167.50	364048	464039
162.50 - 205.00	364049	464040	

✓ High-production fine boring

✓ Easy diameter adjustment

✓ Self-balancing

✓ Imperial and metric

FEATURES AN **ENHANCED** CLAMPING MECHANISM FROM OUR TRUSTED LINE OF 565 (564) DIGITAL FINE BORING HEADS

Aluminum bodies with *wear-resistant* coating from 2.559" - 8.071" (65.00 mm - 205.00 mm)



Highly accurate adjustments through *vernier* scale



Equipped with *self-balancing* mechanism

365 (364) / 465 (464) Analog Boring Heads

Diameter Range: 0.787" - 2.579" (20.00 mm - 65.50 mm)



365 (364)
Form 101

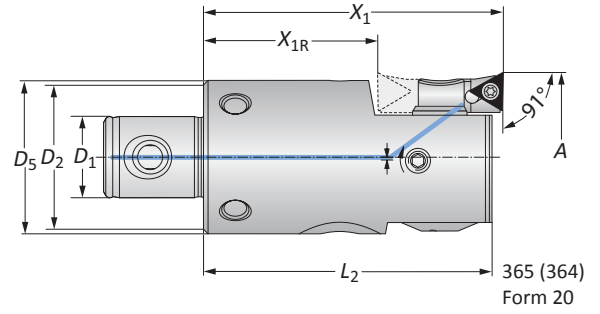
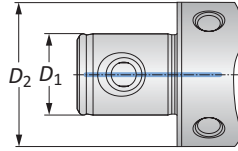

365 (364)
Form 20



465 (464)
Form 101

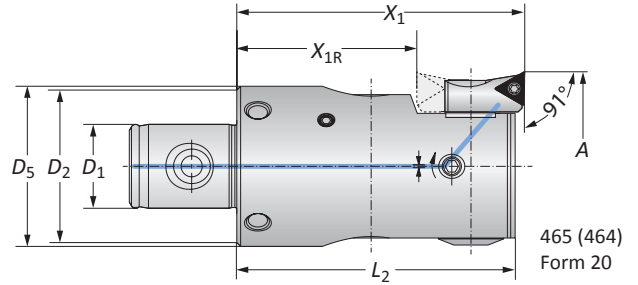

465 (464)
Form 20

365/465 Boring Heads

MVS Connection	Boring Range	Boring Head					Weight	Insert Form	Part No.	
		$D_2 D_1$	A	X_1	X_{1R}	L_2			D_5	Insert Holder
	19 - 11	0.787 - 0.965	1.811	-	1.693	-	0.198 (lbs)	20*	364077	365030
	22 - 11	0.965 - 1.161	1.811	-	1.713	0.906	0.331 (lbs)	20	210059	365031
	22 - 11	0.965 - 1.161	1.811	-	1.713	0.906	0.331 (lbs)	101	210069	365031
	25 - 14	1.142 - 1.516	2.205	-	2.106	1.063	0.441 (lbs)	20	210059	465033
i	25 - 14	1.142 - 1.516	2.205	-	2.106	1.063	0.441 (lbs)	101	210069	465033
	32 - 18	1.496 - 1.988	2.598	1.496	2.450	1.339	0.882 (lbs)	20	264051	465034
	32 - 18	1.496 - 1.988	2.598	1.496	2.450	1.339	0.882 (lbs)	101	264077	465034
	40 - 22	1.969 - 2.579	2.953	1.850	2.854	1.654	1.764 (lbs)	20	210052	465035
	40 - 22	1.969 - 2.579	2.953	1.850	2.854	1.654	1.764 (lbs)	101	210062	465035

*Not suitable for indexable inserts with a radius of 0.031" (0.80 mm)

NOTE: X_{1R} = rotated insert holder for reverse machining

NOTE: Insert holders and inserts sold separately

364/464 Boring Heads

MVS Connection	Boring Range	Boring Head					Weight	Insert Form	Part No.	
		$D_2 D_1$	A	X_1	X_{1R}	L_2			D_5	Insert Holder
	19 - 11	20.00 - 24.50	46.00	-	43.00	-	0.09 (kg)	20*	364077	364030
	22 - 11	24.50 - 29.50	46.00	-	43.50	23.00	0.15 (kg)	20	210059	364031
	22 - 11	24.50 - 29.50	46.00	-	43.50	23.00	0.15 (kg)	101	210069	364031
	25 - 14	29.00 - 38.00	56.00	-	53.50	27.00	0.20 (kg)	20	210059	464033
m	25 - 14	29.00 - 38.00	56.00	-	53.50	27.00	0.20 (kg)	101	210069	464033
	32 - 18	38.00 - 50.00	66.00	38.00	63.50	34.00	0.40 (kg)	20	264051	464034
	32 - 18	38.00 - 50.00	66.00	38.00	63.50	34.00	0.40 (kg)	101	264077	464034
	40 - 22	50.00 - 65.50	75.00	47.00	72.50	42.00	0.80 (kg)	20	210052	464035
	40 - 22	50.00 - 65.50	75.00	47.00	72.50	42.00	0.80 (kg)	101	210062	464035

*Not suitable for indexable inserts with a radius of 0.031" (0.80 mm)

NOTE: X_{1R} = rotated insert holder for reverse machining

NOTE: Insert holders and inserts sold separately

B10-M: 12-15

B10-F

B10: vi-vii

Key on B10-B: 1

i = Imperial (in)
m = Metric (mm)

IMPORTANT: Max spindle speed refers to maximum possible speed for an individual boring head and is not a recommended parameter. Refer to page B10-M: 12 for recommended application-specific parameters. Factory technical assistance is available for your specific applications through our Application Engineering department.
ext: 7611 | email: appeng@alliedmachine.com

465 (464) Analog Boring Heads

Alu-Line | Diameter Range: 2.559" - 8.071" (65.00 mm - 205.00 mm)



Form 101

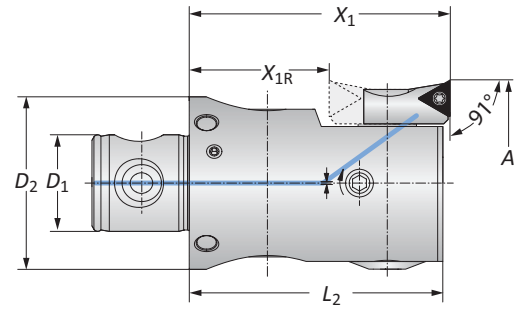
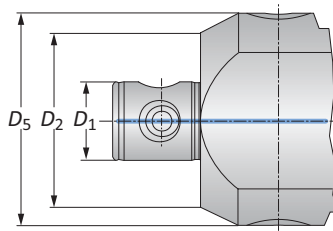

Form 20

465 Alu-Line Boring Heads

MVS Connection	Boring Range	Boring Head				Weight	Insert Form	Part No.	
		$D_2 D_1$	A	X_1	X_{1R}			L_2	D_5
50 - 28	2.559 - 3.268	2.953	1.535	2.854	-	1.323 (lbs)	20	210020	465036
50 - 28	2.559 - 3.268	2.953	1.535	2.854	-	1.323 (lbs)	101	210063	465036
50 - 28	2.559 - 3.268	2.953	1.535	2.854	-	1.323 (lbs)	103	210064	465036
63 - 36	3.228 - 4.055	3.543	2.126	3.445	-	2.205 (lbs)	20	210020	465037
63 - 36	3.228 - 4.055	3.543	2.126	3.445	-	2.205 (lbs)	101	210063	465037
63 - 36	3.228 - 4.055	3.543	2.126	3.445	-	2.205 (lbs)	103	210064	465037
80 - 36	3.937 - 5.118	3.543	2.126	3.445	-	3.307 (lbs)	20	210020	465038
80 - 36	3.937 - 5.118	3.543	2.126	3.445	-	3.307 (lbs)	101	210063	465038
80 - 36	3.937 - 5.118	3.543	2.126	3.445	-	3.307 (lbs)	103	210064	465038
80 - 36	4.921 - 6.594	3.543	2.126	3.445	3.937	4.189 (lbs)	20	210020	465039
80 - 36	4.921 - 6.594	3.543	2.126	3.445	3.937	4.189 (lbs)	101	210063	465039
80 - 36	4.921 - 6.594	3.543	2.126	3.445	3.937	4.189 (lbs)	103	210064	465039
80 - 36	6.398 - 8.071	3.543	2.126	3.445	5.315	5.512 (lbs)	20	210020	465040
80 - 36	6.398 - 8.071	3.543	2.126	3.445	5.315	5.512 (lbs)	101	210063	465040
80 - 36	6.398 - 8.071	3.543	2.126	3.445	5.315	5.512 (lbs)	103	210064	465040

NOTE: X_{1R} = rotated insert holder for reverse machining

NOTE: Insert holders and inserts sold separately

464 Alu-Line Boring Heads

MVS Connection	Boring Range	Boring Head				Weight	Insert Form	Part No.	
		$D_2 D_1$	A	X_1	X_{1R}			L_2	D_5
50 - 28	65.00 - 83.00	75.00	39.00	72.50	-	0.60 (kg)	20	210020	464036
50 - 28	65.00 - 83.00	75.00	39.00	72.50	-	0.60 (kg)	101	210063	464036
50 - 28	65.00 - 83.00	75.00	39.00	72.50	-	0.60 (kg)	103	210064	464036
63 - 36	82.00 - 103.00	90.00	54.00	87.50	-	1.00 (kg)	20	210020	464037
63 - 36	82.00 - 103.00	90.00	54.00	87.50	-	1.00 (kg)	101	210063	464037
63 - 36	82.00 - 103.00	90.00	54.00	87.50	-	1.00 (kg)	103	210064	464037
80 - 36	100.00 - 130.00	90.00	54.00	87.50	-	1.50 (kg)	20	210020	464038
80 - 36	100.00 - 130.00	90.00	54.00	87.50	-	1.50 (kg)	101	210063	464038
80 - 36	100.00 - 130.00	90.00	54.00	87.50	-	1.50 (kg)	103	210064	464038
80 - 36	125.00 - 167.50	90.00	54.00	87.50	100.00	1.90 (kg)	20	210020	464039
80 - 36	125.00 - 167.50	90.00	54.00	87.50	100.00	1.90 (kg)	101	210063	464039
80 - 36	125.00 - 167.50	90.00	54.00	87.50	100.00	1.90 (kg)	103	210064	464039
80 - 36	162.50 - 205.00	90.00	54.00	87.50	135.00	2.50 (kg)	20	210020	464040
80 - 36	162.50 - 205.00	90.00	54.00	87.50	135.00	2.50 (kg)	101	210063	464040
80 - 36	162.50 - 205.00	90.00	54.00	87.50	135.00	2.50 (kg)	103	210064	464040

NOTE: X_{1R} = rotated insert holder for reverse machining

NOTE: Insert holders and inserts sold separately

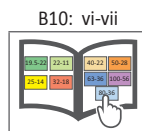
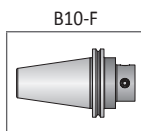
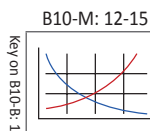

Key on B10-B-1

i = Imperial (in)
m = Metric (mm)

IMPORTANT: Max spindle speed refers to maximum possible speed for an individual boring head and is not a recommended parameter. Refer to page B10-M: 12 for recommended application-specific parameters. Factory technical assistance is available for your specific applications through our Application Engineering department.
ext: 7611 | email: appeng@alliedmachine.com

Insert Holders for Abrasive Materials

Diameter Range: 2.559" - 8.071" (65.00 mm - 205.00 mm)

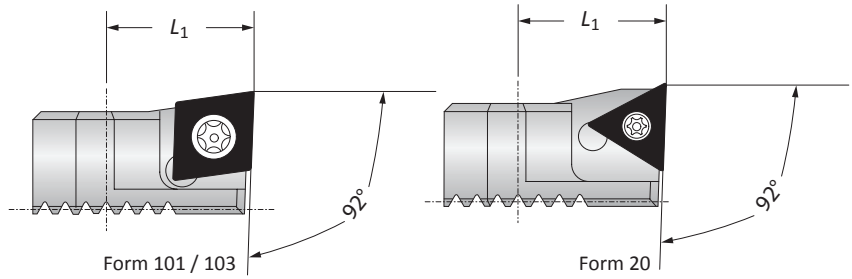

		Insert Holder			
Boring Range		L_1	Weight	Insert Form	Part No.
i	2.559 - 8.071	0.709	0.066 (lbs)	20	211061
	2.559 - 8.071	0.709	0.066 (lbs)	101	211063
	2.559 - 8.071	0.709	0.066 (lbs)	103	211065
m	65.00 - 205.00	18.00	0.03 (kg)	20	211061
	65.00 - 205.00	18.00	0.03 (kg)	101	211063
	65.00 - 205.00	18.00	0.03 (kg)	103	211065

NOTE: Insert holders used for abrasive materials to protect boring head against chip wash

NOTE: When machining grey cast iron, we recommend using insert holders for abrasive materials with CBN inserts for optimized chip removal.

B10-M: 12-15

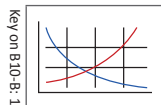

B10-H

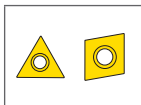

B10: vi-vii

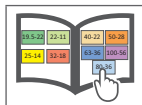

i = Imperial (in)
m = Metric (mm)

Inserts sold separately

Accessories

Screws

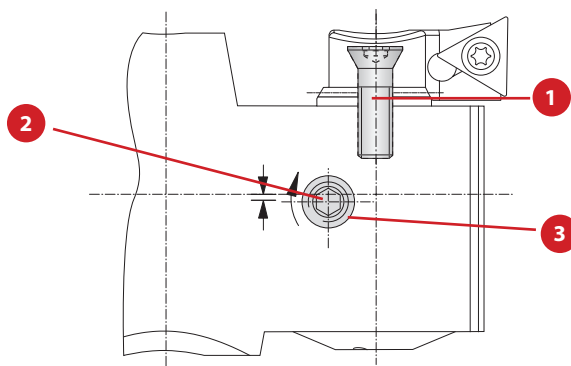

Boring Head	Part No.				
	1 Countersunk Screw	Countersunk Screw Service Key	2 Clamping Screw	Clamping Screw Service Key	3 Ball
365030 (364030)	215323	T15 / H	364260	s2 / A	364270
365031 (364031)	215338	T15 / H	364138	s2.5 / A	364139
465033 (464033)	215338	T15 / H	364138	s2.5 / A	364139
465034 (464034)	215338	T15 / H	115180	s2.5 / A	-
465035 (464035)	215338	T15 / H	115505	s3 / B	-
465036 (464036)	215462	T20 / H	315943	s4 / B	-
465037 (464037)	215462	T20 / H	515178	s4 / B	-
465038 (464038)	215462	T20 / H	515178	s4 / B	-
465039 (464039)	215462	T20 / H	515178	s4 / B	-
465040 (464040)	215462	T20 / H	515178	s4 / B	-

A

B

C

D

E

F

G

H

I

J

K

L

M

INDEX

